



GREYBIRCH **MFG.CO**

LaChassis T1X

NOT YOUR ORDINARY COMPANY

All Grey Birch products are made with an obsessive focus on design and functionality.

When you purchase a Grey Birch product, not only are you supporting a small business directly, you are supporting many small businesses indirectly.

By manufacturing locally, it allows us to be as close to the process as possible to ensure the highest level of quality is achieved.

We are confident and proud to be putting out world class products that you can enjoy for a lifetime ... and then pass down to the next generation.

Welcome to the Grey Birch family.

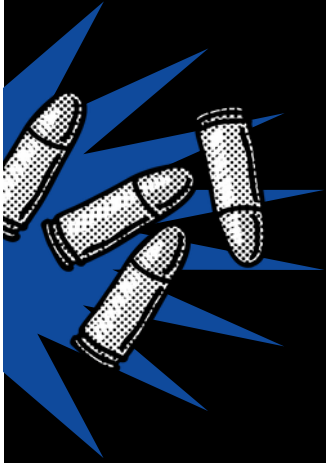

We don't take ourselves too seriously, but one thing we don't mess around with is firearm safety.

Firearms Safety 101

- Assume every firearm is loaded.
- Control the muzzle direction at all times.
- Always point your firearm in a safe direction.

Remove the magazine from the firearm.

- Observe the chamber to ensure it is empty.
- Open the bolt and remove from the action if possible.
- Once your firearm has been proven safe you can begin modifying or cleaning.

Please ensure approved eye and ear protection is worn at all times.

*Be aware of the laws in your country and region concerning overall rifle length and folding stocks. It is up to you — the end user to ensure you maintain compliance.

Grey Birch ships all stocks in the fixed position.



INSTALLING THE ACTION INTO THE CHASSIS

We already know you're a refined and discerning individual. How? Because you've made the phenomenal decision to purchase this chassis. It'll turn your basic T1X into something that'll get more 'double takes' than Tyra Banks circa 1997.

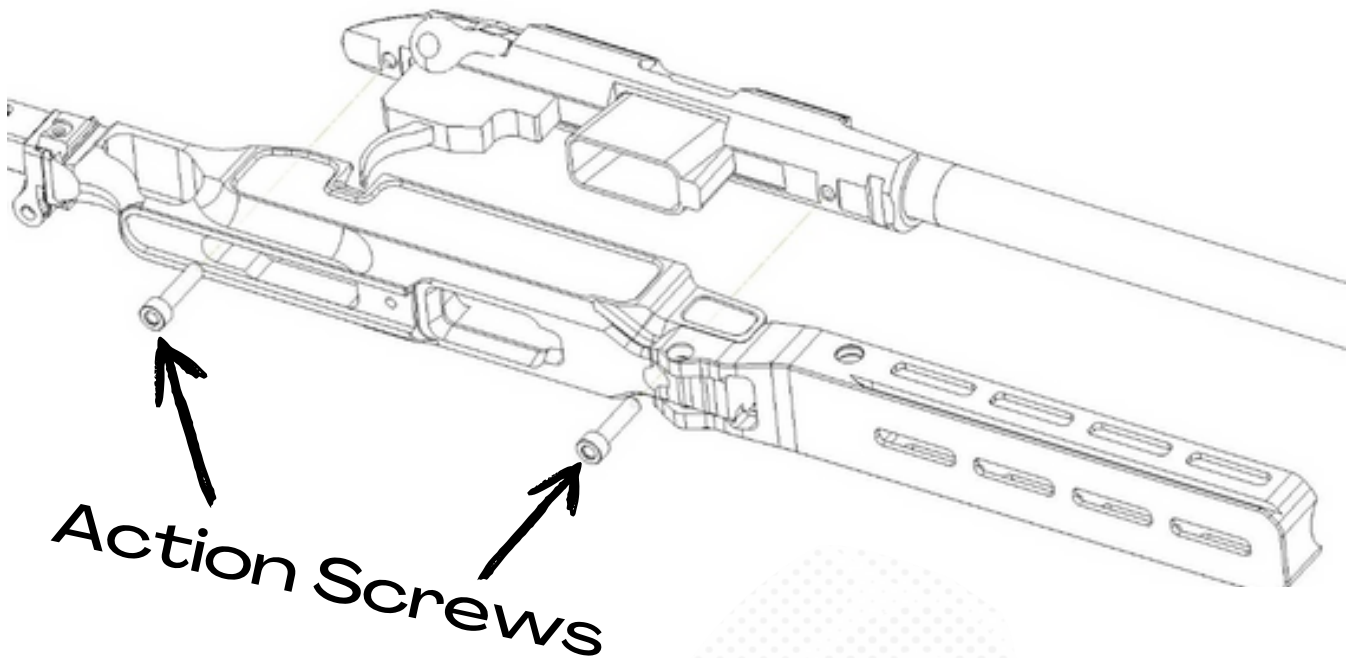

STEPS TO FOLLOW

- Remove your T1X barreled action from the factory stock by undoing the two screws in the trigger guard. You will no longer need these screws.
- Remove the barreled action from the stock and re-install into the Foundation T1X Chassis. The simplest method is to rest the barreled action upside down on a flat surface and place the chassis on top of it.
- Ensure the trigger guard is removed so you can access the rear action screw hole located behind the trigger.
- With the chassis placed on top of the barreled action, install the included action screws as shown in the diagram. These screws are identical.
- Using a 3/16" hex key, lightly snug both screws equally before torquing to 40 in/lb.

ATTACHING THE TRIGGER GUARD

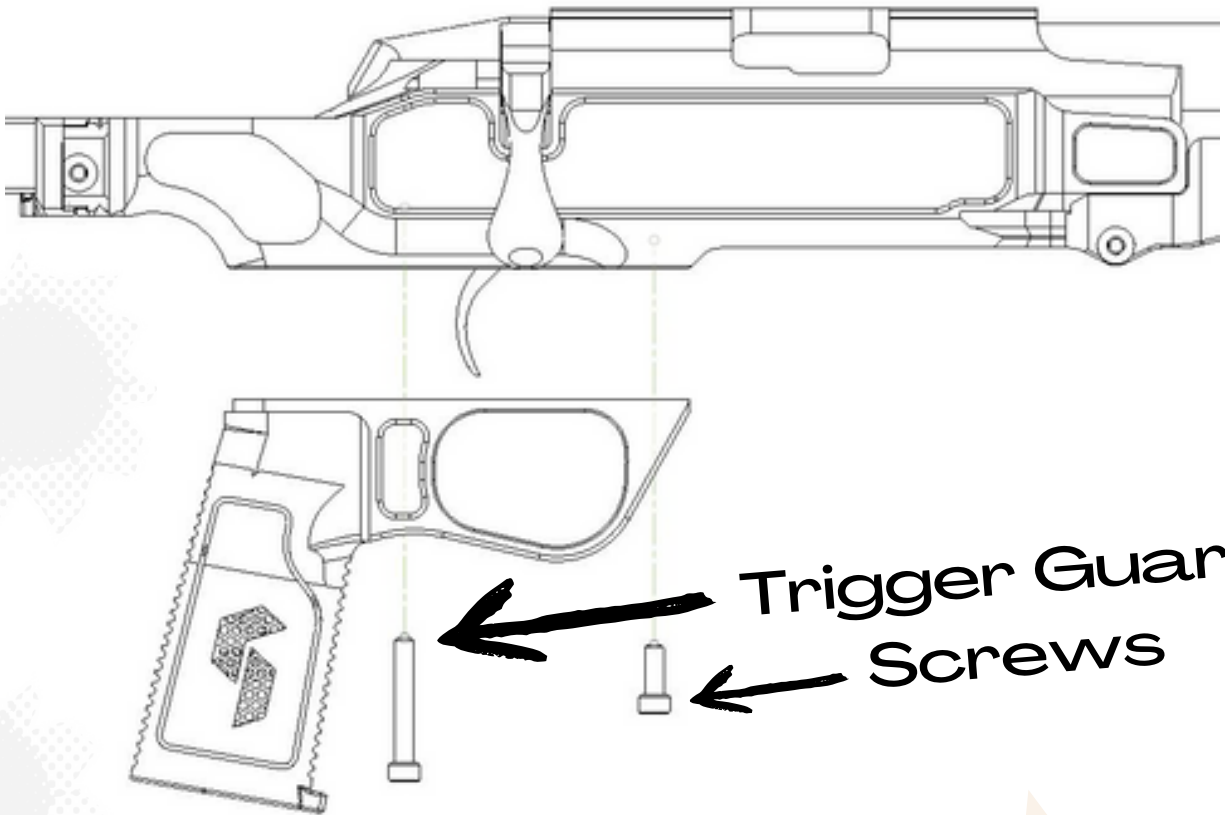

STEPS TO FOLLOW

- With the action installed, the trigger guard can now be attached.
- Fit the trigger guard into the mating slot on the bottom of the chassis body.
- Insert the provided trigger guard screws into their holes using a 5/32" hex key. The longer screw goes in the rear of the guard, and the short screw in the front as shown in the diagram.
- Be careful not to cross-thread the screws. Tighten to 25 in/lbs.

INSTALLING/ REMOVING THE FOREND

DID YOU KNOW

The founders of Grey Birch grew up shooting with their fathers and grandfathers - bonafide 3rd generation plinkers.

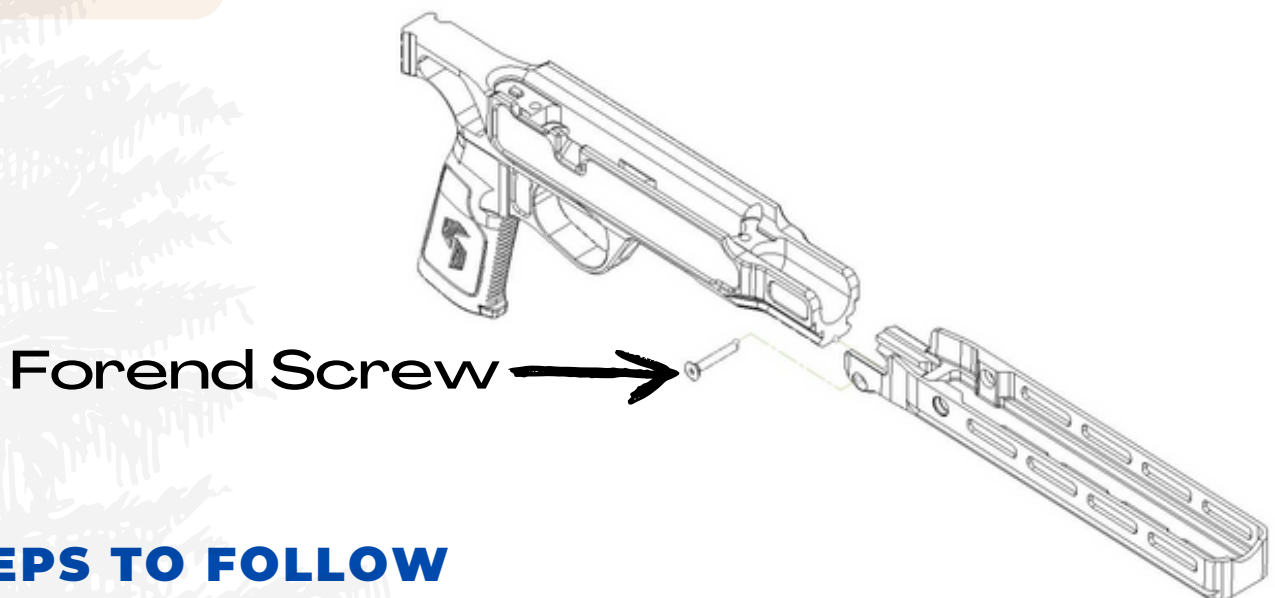

STEPS TO FOLLOW

- Slide the forend over the dove tail on the front of the chassis.
- You may need to slightly wiggle it while sliding it on. ("That's what she said" - Michael G. Scott)
- When the forend is in place, install the screw using a 3/32" hex key and tighten to 15 in/lbs.
- Do not over tighten as it may damage the threads of the forend.
- To remove the forend, follow these steps in reverse.

INSTALLING/ REMOVING THE STOCK

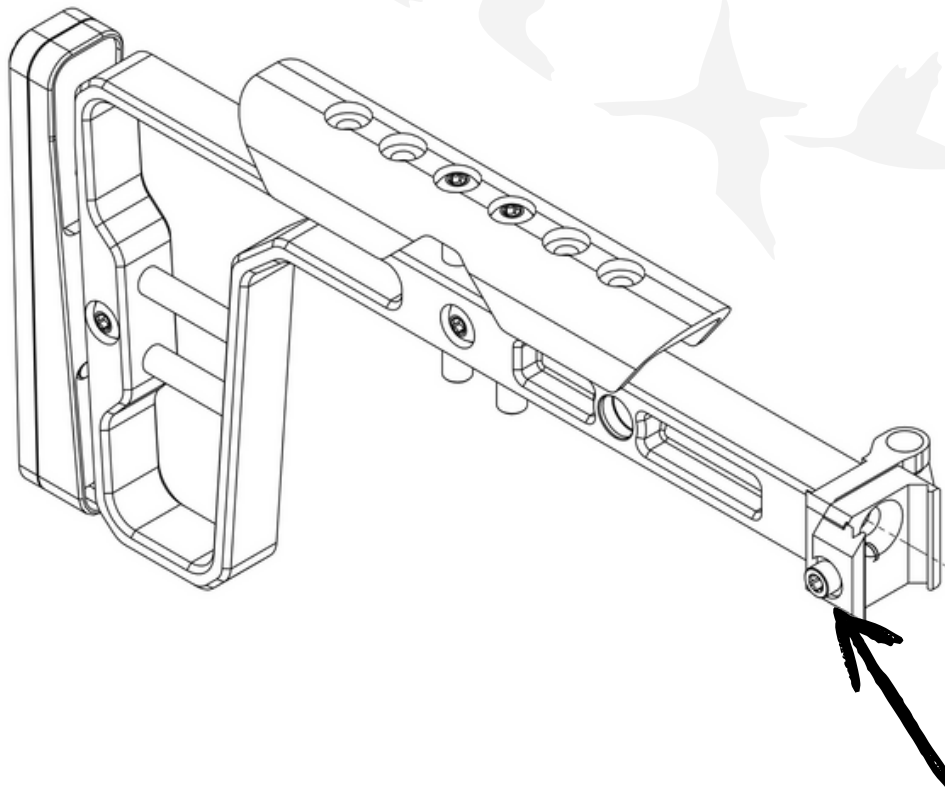

Adapter Clamp
Screw

STEPS TO FOLLOW

- Using a 3/32" hex key, loosen the screw until the claw opens enough to clear the picatinny mounting face.
- To install, tighten the screw until the claw closes on the picatinny mounting face.
- Continue to tighten the screw until the stock is secure to the chassis.
- Tighten to 15 in/lbs.



ADJUSTING THE CHEEK WELD LOCATION

DID YOU KNOW

The founders of Grey Birch are diehard fans of sport shooting -- the only problem? They can barely hit a beach ball at 50 yds.

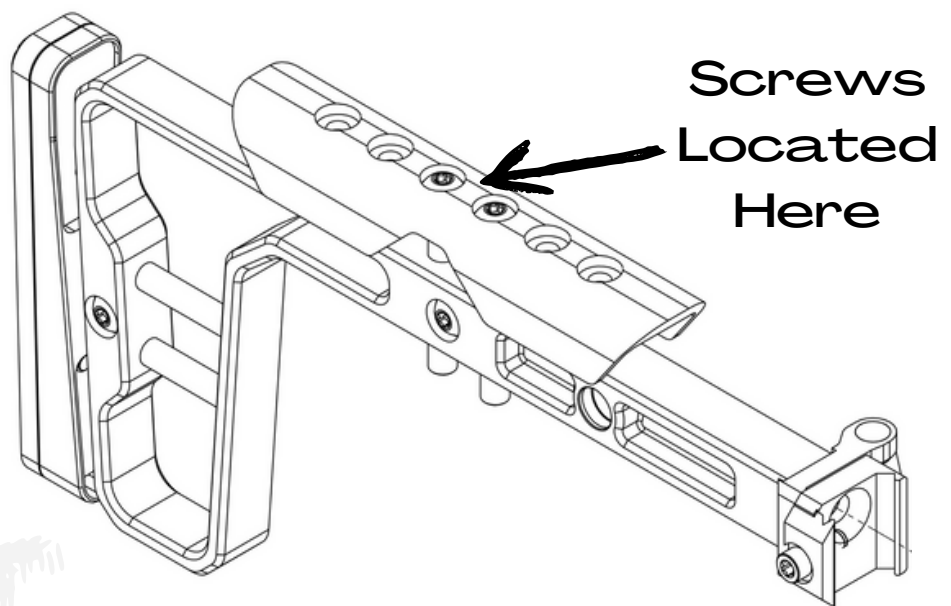

STEPS TO FOLLOW

- Using a 1/8" hex key, remove the two screws on the top of the cheek weld. Don't lose those pillars.
- With the screws removed, shift the position of the cheek weld forward or backwards as desired.
- With the cheek weld in position, tighten the two screws through the cheek weld into the pillars behind it.
- Hand tighten only.

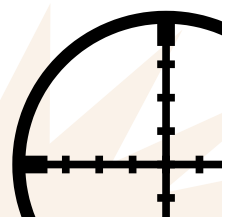

ADJUSTING THE CHEEK WELD HEIGHT

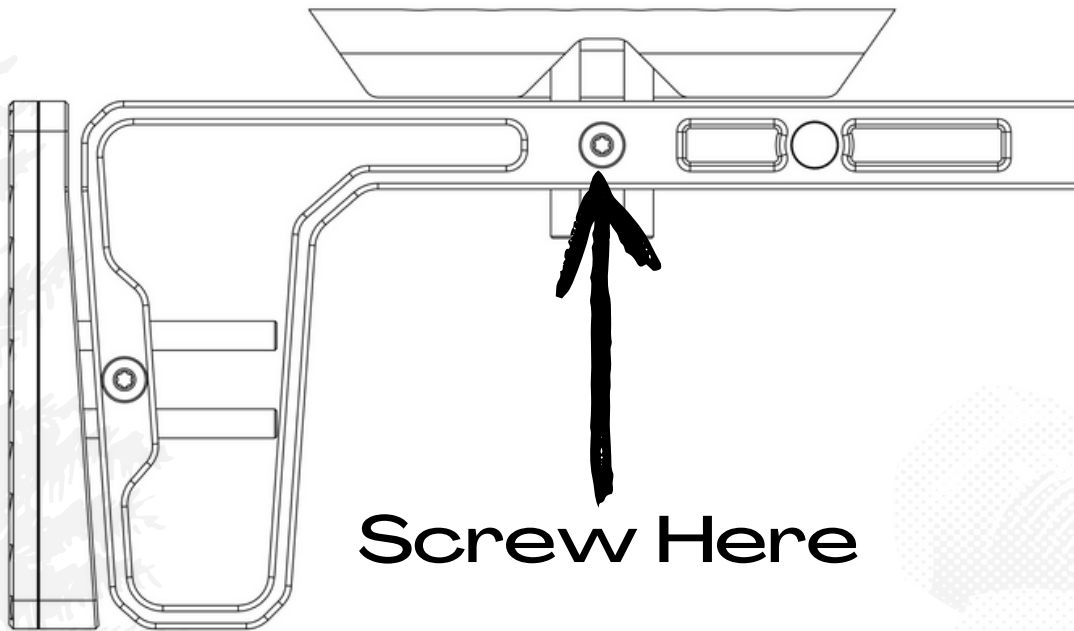

STEPS TO FOLLOW

- Using a 1/8" hex key, loosen off the screw to allow vertical movement of the check weld.
- When the desired height is achieved, tighten the screw to hand tight.
- Do not over tighten as it can damage the threads on the backer plate.
- Tighten to max 15 in/lbs.

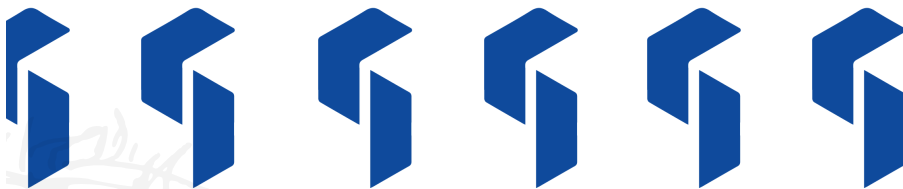

ADJUSTING LENGTH OF PULL

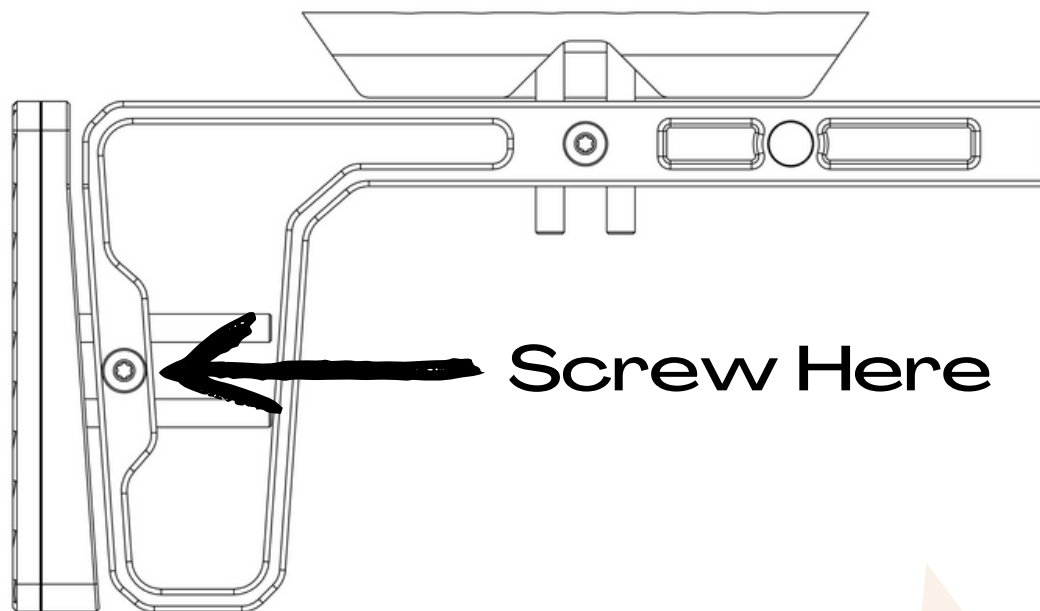

STEPS TO FOLLOW

- Using a 1/8" hex key, loosen off the screw to allow horizontal movement of the shoulder plate.
- When the desired length of pull is achieved, tighten the screw to hand tight.
- Do not over tighten as it can damage the threads on the backer plate.
- Tighten to 15 in/lbs.

STOCK CHANGE: FIXED TO FOLDING

STEPS TO FOLLOW PT.1

- Remove the stock from the chassis by unscrewing the adapter clamp screw using a $3/32$ " hex key.
- Once stock is removed, unscrew the lock out screw using a $5/32$ " hex key.
- Once complete, the stock is now folding enabled.

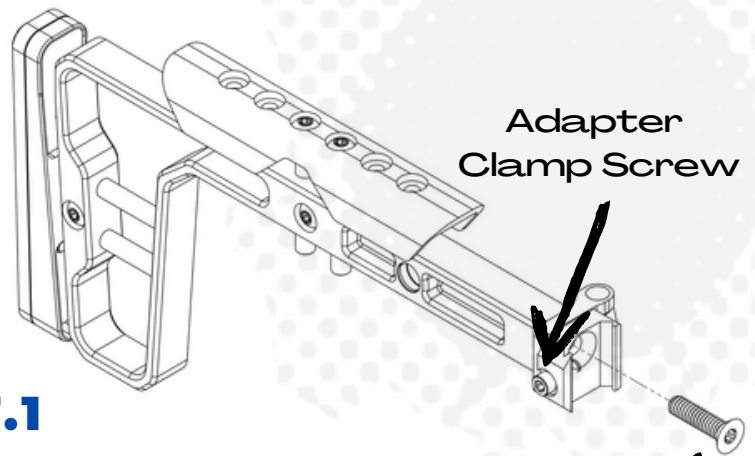

Lock Out
Screw

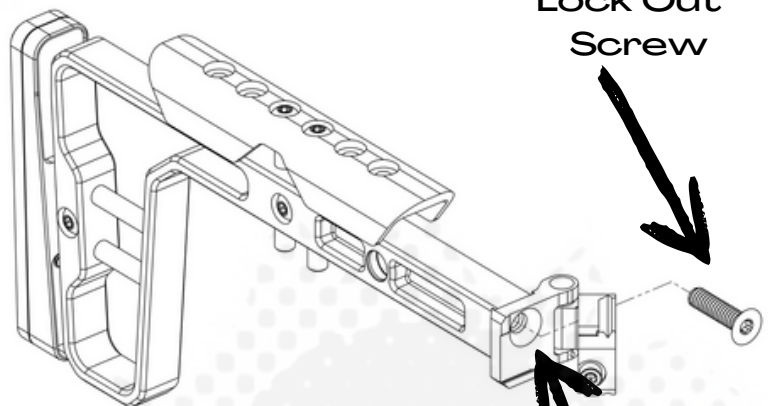

STEPS TO FOLLOW PT.2

- Now with the lock out screw removed, open the mounting face of the adapter to reveal a second location for the lock out screw to be fastened to the stock.
- Using the same $5/32$ " hex key, fasten the lock out screw to the inside mounting face. Tighten to 40 in/lbs.
- This will allow the stock to open and close as required.
- Over time, the lock out screw may need re-tightening.

Mounting
Face

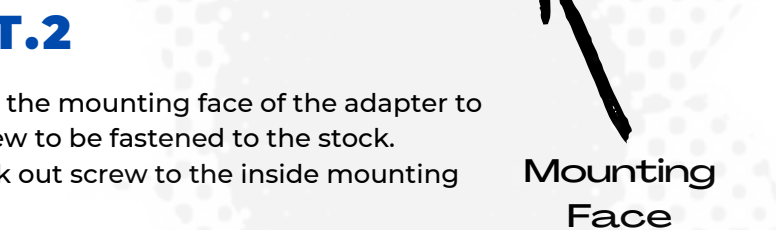

OPERATING THE FOLDING STOCK

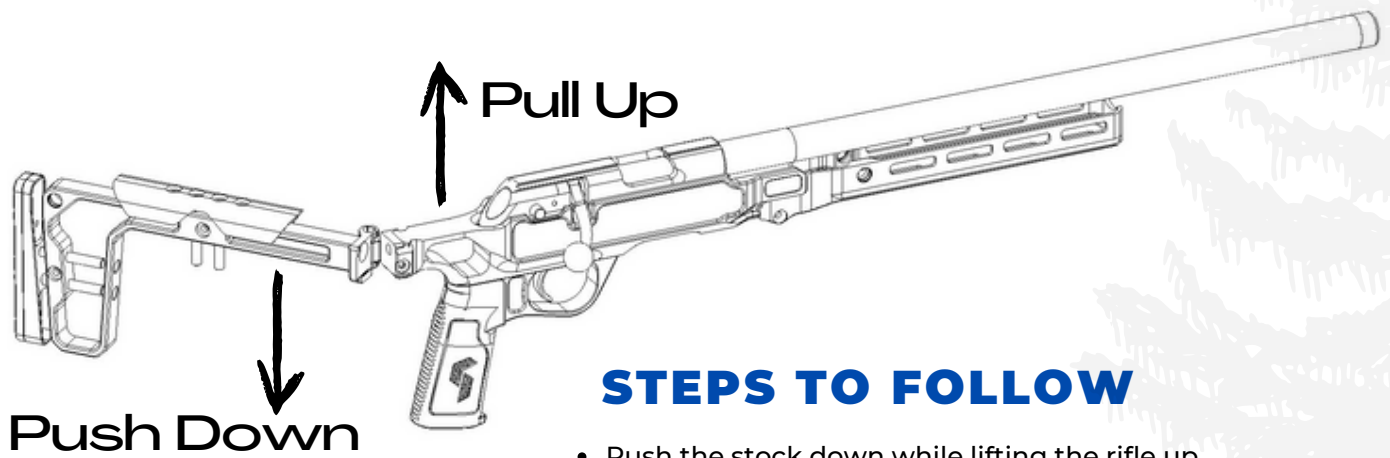

STEPS TO FOLLOW

- Push the stock down while lifting the rifle up.
- The stock will swing towards the rifle into the folded

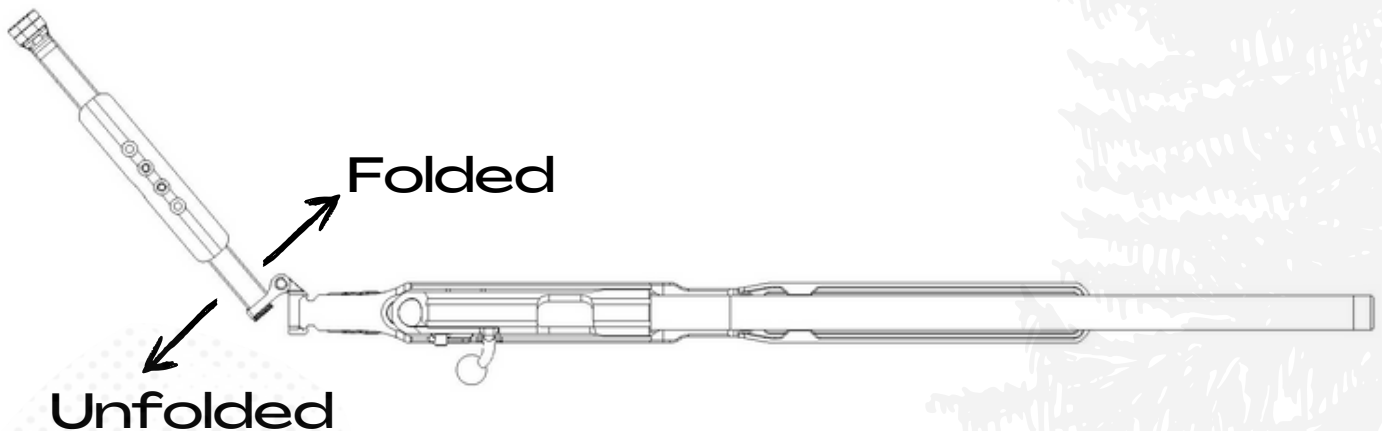



DID YOU KNOW

Grey birches were a favourite tree of the grandfather of one of the company founders.



GEBMFG.CO

  @greybirchsolutions

Tikka TIX is a registered trademark of SAKO LTD.